

VIVOHOME

**THANK
YOU!**

NOTE:

To continuously improve its products, VIVOHOME reserves the right to modify this information without prior notification.

For any questions regarding assembly, please watch the video on the product page or contact our customer service. Our customer service will gladly assist you with any additional questions, comments, or concerns.

Thank you for using VIVOHOME products in your home!

Thank You for Purchasing from

VIVOHOME

Made in China

VIVOHOME

HOW-TO

USER MANUAL

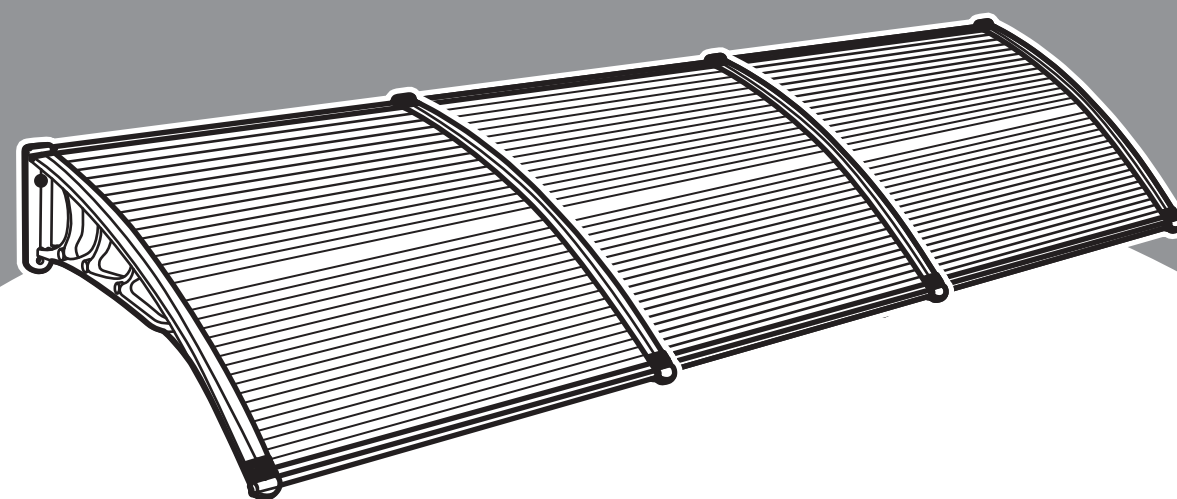

**Polycarbonate Door Awning
40 Inch x 120 Inch**

Assembly is EASY!

**WE WANT
YOU TO
ENJOY LIFE
AT HOME**

GO TO THE PRODUCT LISTING PAGE FOR
AN INSTRUCTIONAL VIDEO!

CONTENTS

Before You Start	1
Parts List and Diagram	1
Assembly Steps.....	3
Return/Damage Claim Instructions.....	10
Warranty	11



1. Please read all instructions carefully.
2. Retain instructions for future reference.
3. Separate and count all parts and hardware.
4. Read through each step carefully and follow the proper order.
5. We recommend that, where possible, all items are assembled near to the area in which they will be placed for use, to avoid moving the product unnecessarily once assembled.
6. Always place the product on a flat, steady and stable surface.
7. Keep all small parts and packaging materials for this product away from babies and children, as they potentially pose a serious choking hazard.



Item No.	Reference Image	Qty.
A		x6
C		x3

Item No.	Reference Image	Qty.
B		x4
D		x3



Item No.	Reference Image	Qty.
E		x3
G	 M4*16 +1(spare)	x18

Item No.	Reference Image	Qty.
F	 M4*35 +1(spare)	x8
H		x8

Installation on wooden houses is not recommended.

Tools recommended.

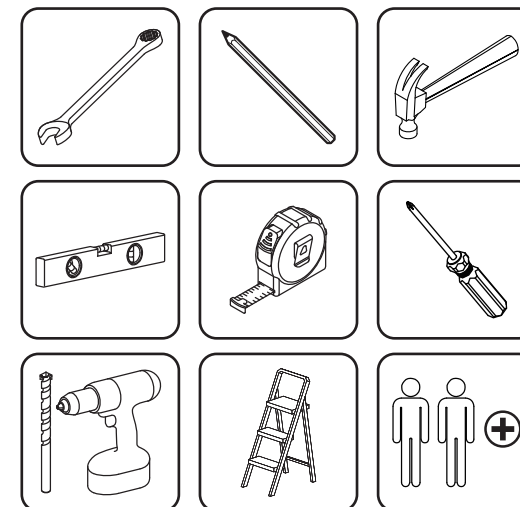



STEP 1 **A** x 6 pcs. **C** x 3 pcs. **D** x 3 pcs. **E** x 3 pcs.

X3

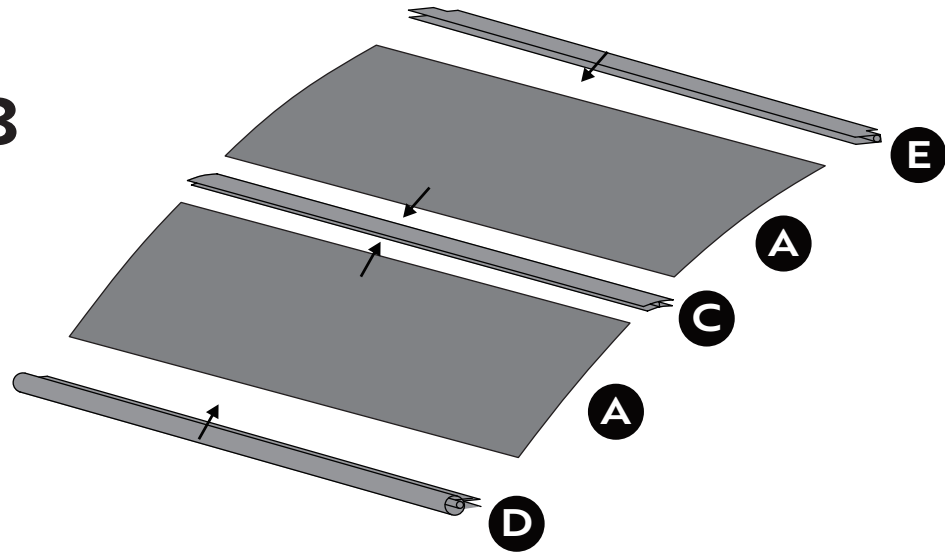

STEP 2 **B** x 2 pcs.

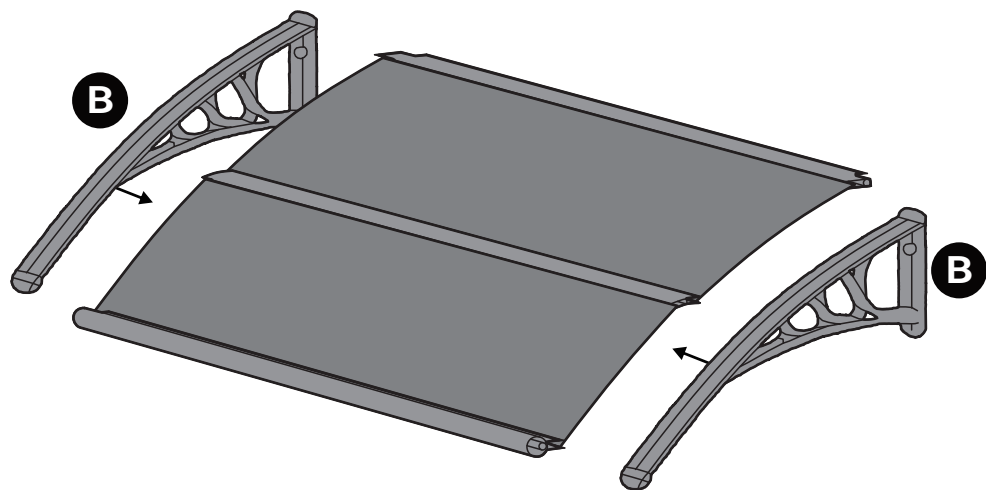

STEP 3 **F** x 4 pcs. **G** x 6 pcs.

Do not confuse similar screws.

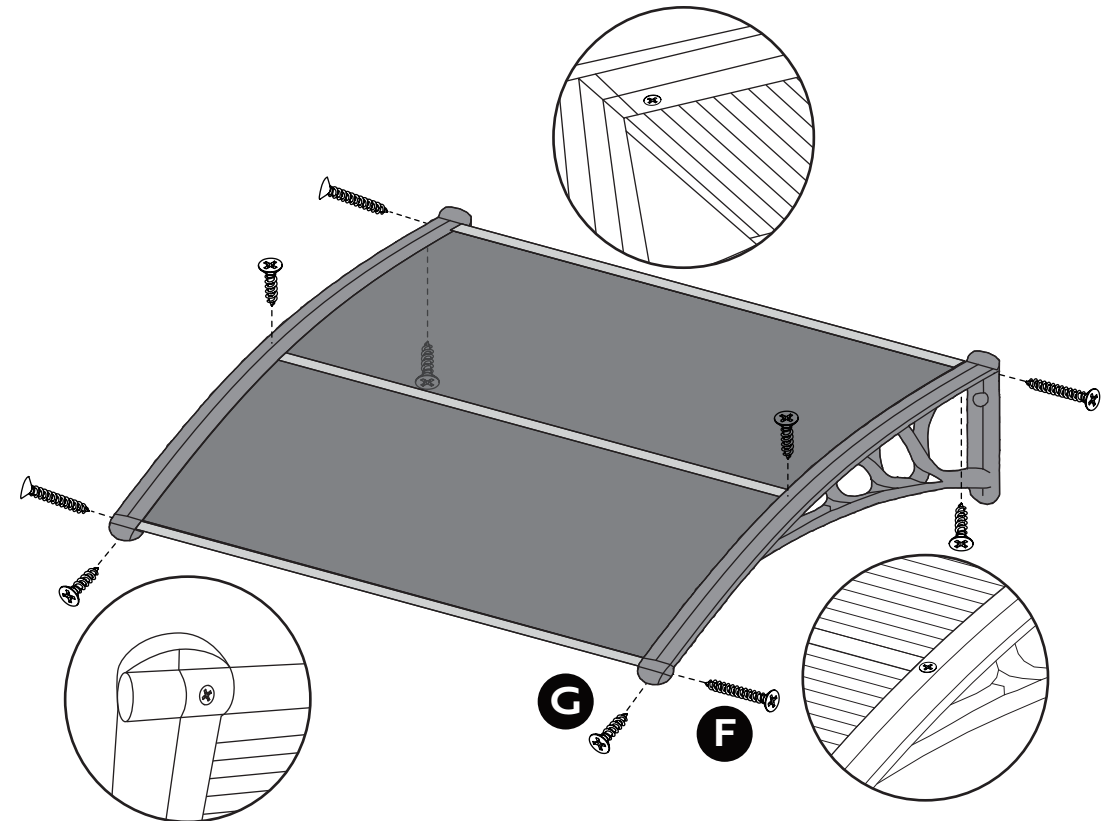



STEP 5 **B** x 1 pc.

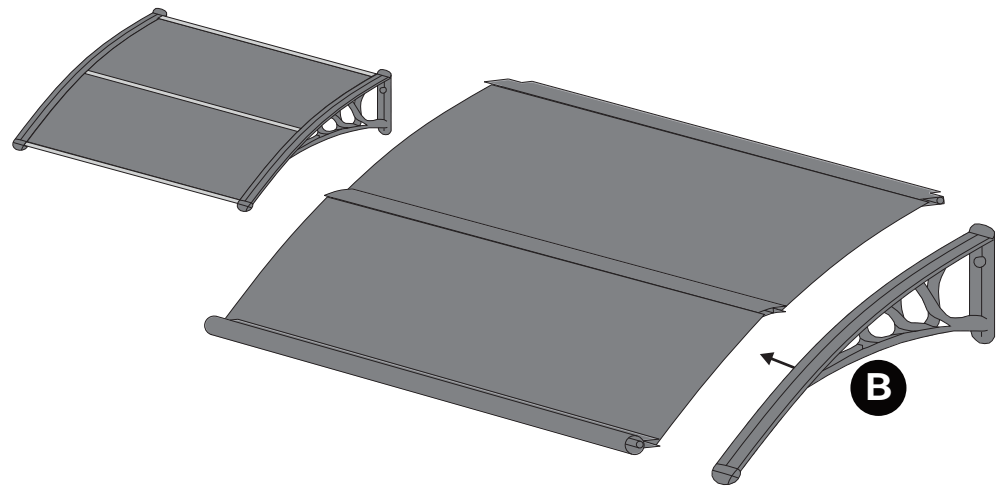

STEP 6

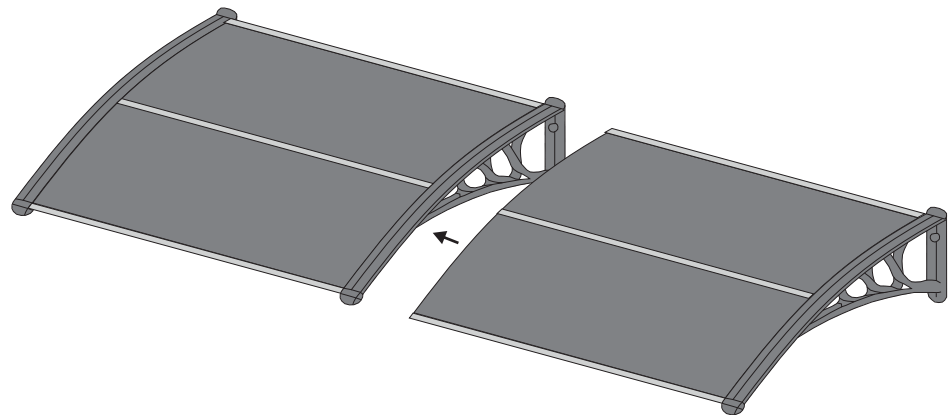

STEP 7 **F** x 2 pcs. **G** x 6 pcs.

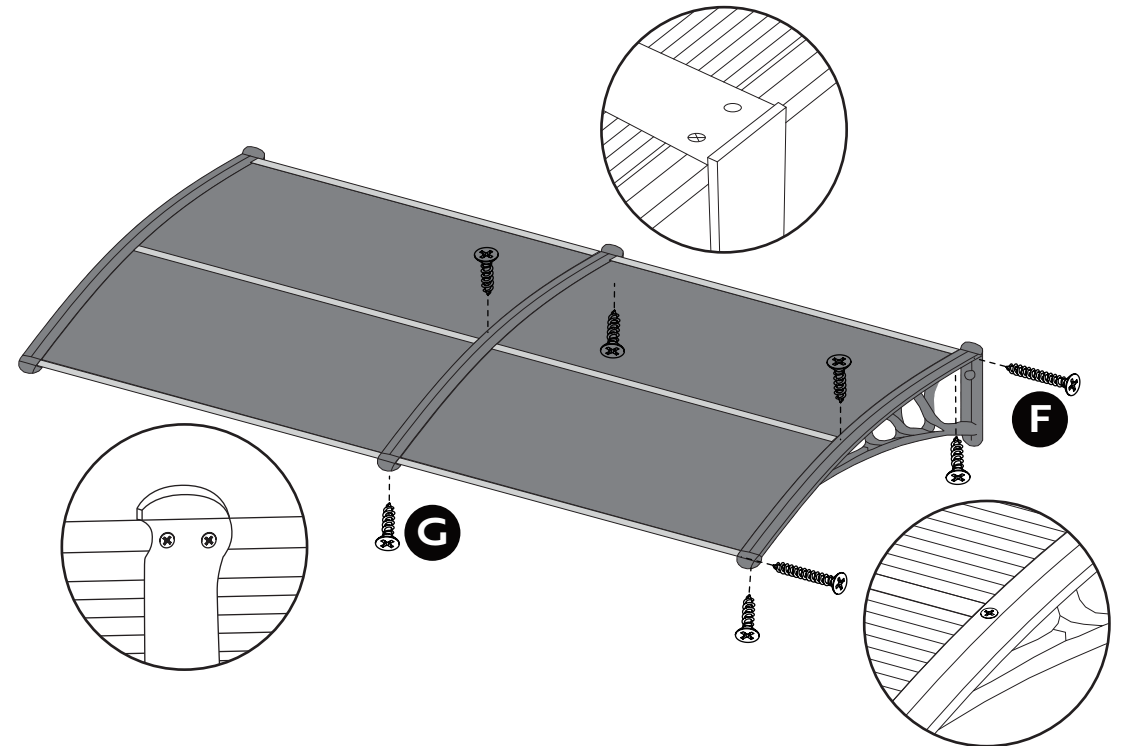

STEP 8 **B** x 1 pc.

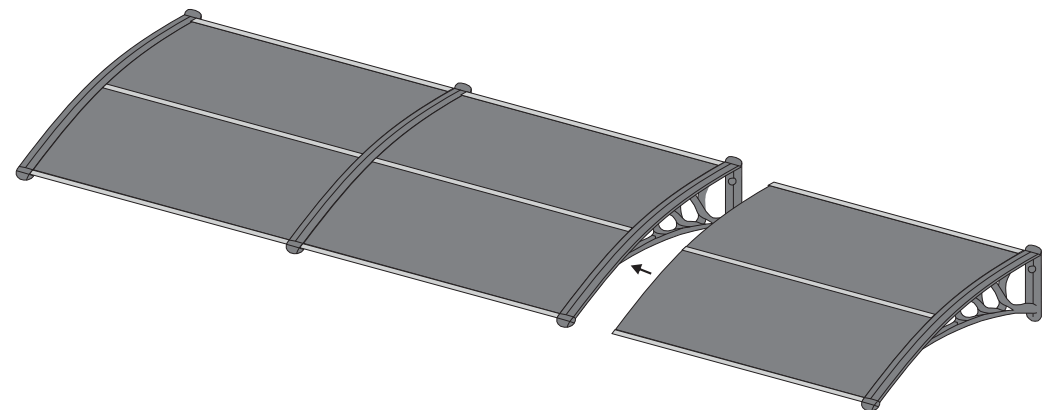

Assembly Steps



STEP 9 **F** x 2 pcs. **G** x 6 pcs.

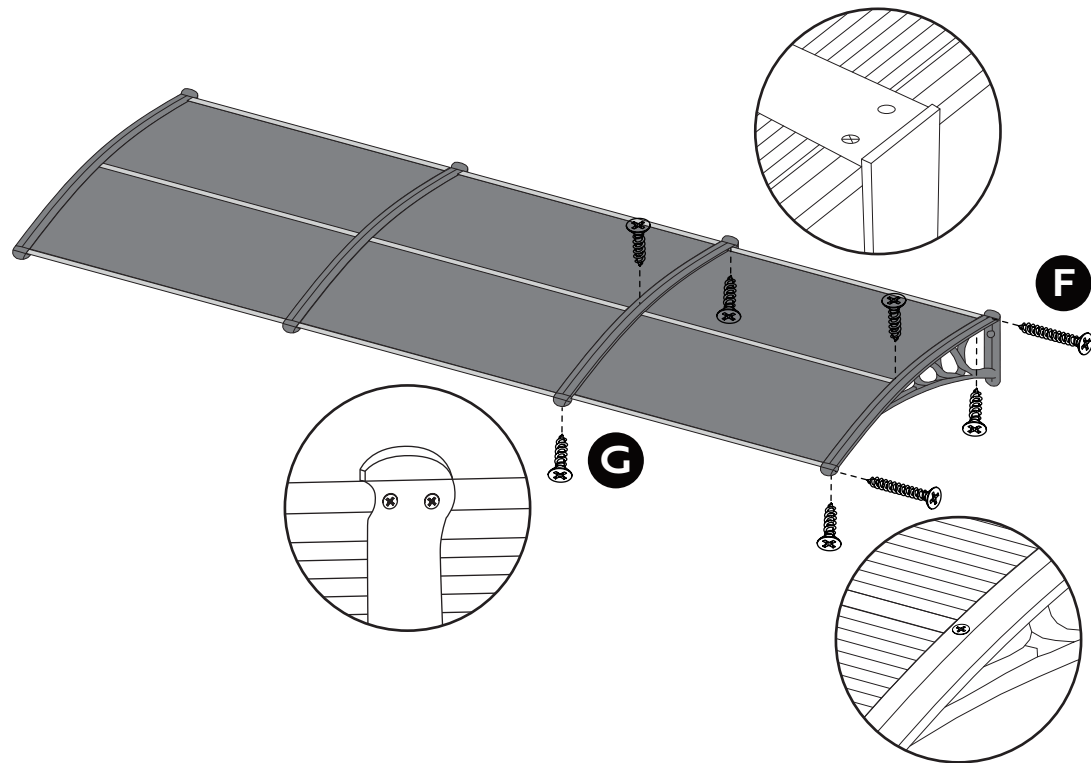

Assembly Steps



STEP 10 **H** x 8 pcs.

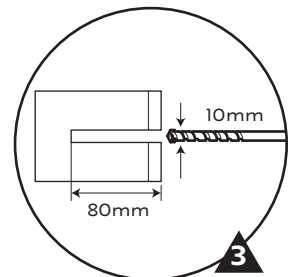
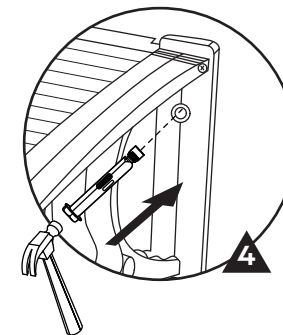
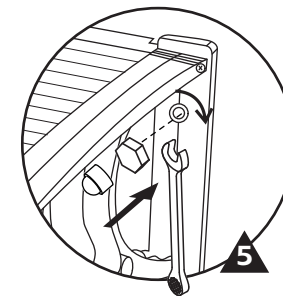
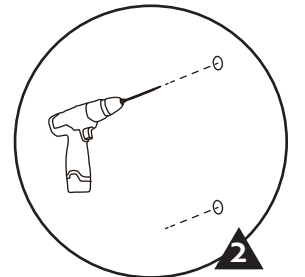
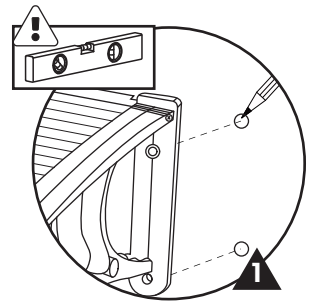
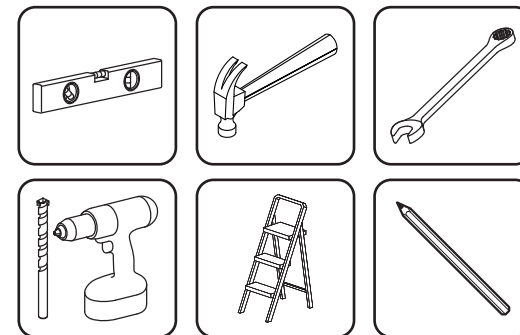
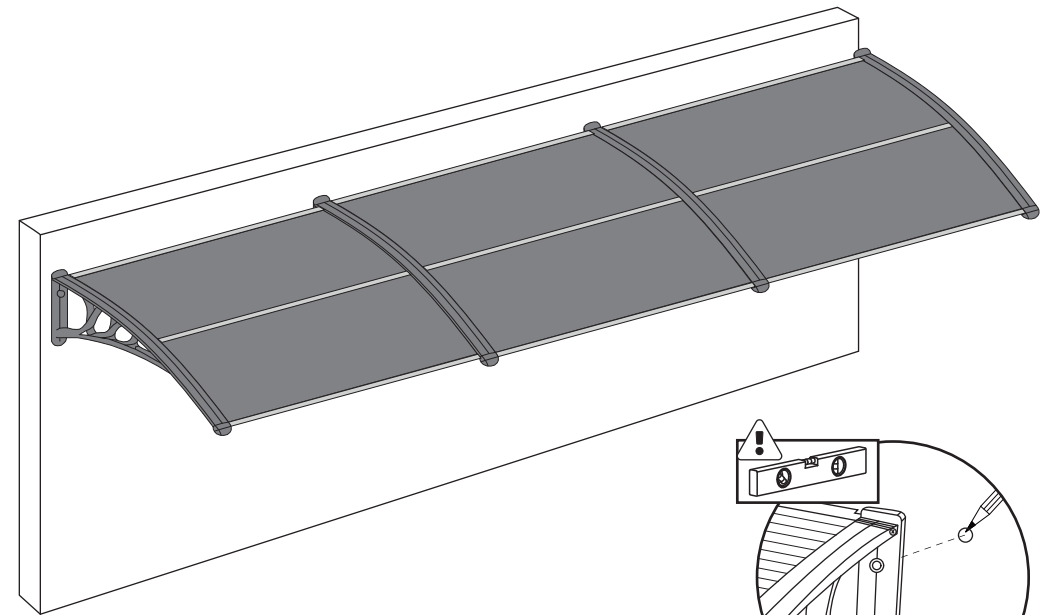

**STEP 11**

Done

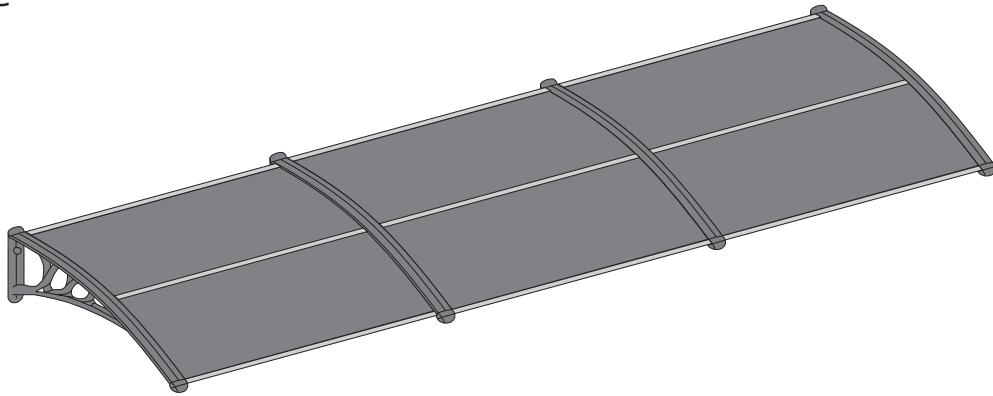

- 1. DO NOT discard the box / original packaging.**
In the event of a return, please ensure that the item is returned in its original package. Returns without the original package will not be accepted.
- 2. Take a photo of the box markings.**
A photo of the markings (text) on the side of the box is required in case a part replacement is needed. This helps our staff identify your product number to ensure you receive the correct parts.
- 3. Take a photo of the damaged part (if applicable).**
A photo of the damage is always required to file a claim and get your replacement or refund processed quickly. Please make sure you have the box even if it is damaged.
- 4. Send us an email with the images requested.**
Email us directly from marketplace where your item was purchased. Please attach the images and provide a description of your claim.



The VIVOHOME warranty program is our commitment to you. We are committed to providing you with a high-quality product that meets your needs and expectations. To demonstrate our confidence in the durability and performance of our products, we offer the following warranty.

WARRANTY COVERAGE

This warranty program applies to any orders, purchases, receipts, or use of any products sold by VIVOHOME and is valid for a period of 1 year from the date of purchase. However, please note that this warranty period is only valid for the original order. If you receive a replacement order during the warranty period, it will not include a separate warranty period.

WARRANTY EXCLUSIONS

This warranty does not cover damage resulting from misuse, accident, unauthorized modification, or any other circumstances not directly related to the manufacturing and design of the product, including but not limited to:

- Parts lost during use.
- Normal wear and tear of products or parts.
- Incorrect installation (such as using the wrong voltage) or assembly.
- Exceeding the bearing capacity of the product.
- Use under extremely harsh conditions.

- Improper cleaning or maintenance.
- Damage caused by any reason other than the intended use of the product.
- Indirect loss or damage caused by the product.

HOW TO MAKE A WARRANTY CLAIM

If you find any defects that affect the use of the product or if the product stops working and cannot be repaired during the warranty period, please contact our customer service team at our email or via Amazon & app's direct messaging service as soon as possible. Provide the following information to expedite the process:

- Order number
- Images and/or videos illustrating the issue
- A detailed description of the problem

VIVOHOME will provide technical support, replacement, refund, or other solutions based on the nature of the issue. If you wish to return the original package for any reason, please contact us for confirmation before proceeding. You can expect to receive a response within 48 hours.

Thank you for choosing VIVOHOME. We are committed to ensuring the quality and satisfaction of your purchase. If you have any questions or need assistance, please do not hesitate to contact our customer service team.